



*The PES 6 unit shall always be connected to a filter separator to complete a vacuum system*

## Vacuum Unit PES-6

***The PES Vacuum units meet the high demands from the industry due to its efficiency, reliability, ease of operation and maintenance giving excellent value for money.***

The PES-6 units are a series of free standing vacuum units, to be used in conjunction with any type of filter separator. PES creates the vacuum and air volume needed for conveyance of bulk material or vacuum cleaning operation.

- Electrically powered vacuum pump of side-channel type
- Designed for high vacuum systems (30-40%)
- As standard equipped with safety valve
- Rigid steel construction and insulated housing
- Complete electrical panel for start/stop and controls
- Low noise operation
- Maintenance free operation

### **OPERATION**

All PES-6 units are designed for, and shall always be used together with a filter separator. Vacuumed material shall not reach the PES unit but be collected and filtered in suitable model of filter separator, depending on material to be transported. The benefit of this separate vacuum unit is it can be used in conjunction with any type of filter separator. Connection to filter separator is made through a flexible hose or a fixed steel pipe.

The unit is delivered with an electrical panel comprising all controls for start/stop and operation of the unit, as well as controls for selected filter separator, i.e. filter cleaning, discharging, etc.

### **WHY PES-6**

Highest demand for reliable operation, minimum of service, and easy to operate. Equipped with exhaust silencer and insulated housing for low noise emission. Safety devices for; max vacuum and motor over load is standard. Easy to transport/install with forklift.

### **APPLICATION**

For use in any industrial application where reliable and rigid units are requested for creation of high vacuum and large air volume. PES 6 is designed for stationary installation, and can be used for both indoor and outdoor operation.

### **TYPICAL USERS**

Manufacturers of Cement, Lime, Gypsum, Tiles, Ceramics, Chemicals, Plastics, Pulp- and Paper Industry, Thermo-electric Power Plants, Metal Workshops, Food Industry, Bakeries...

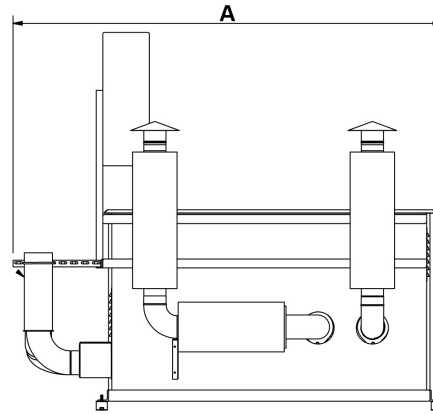
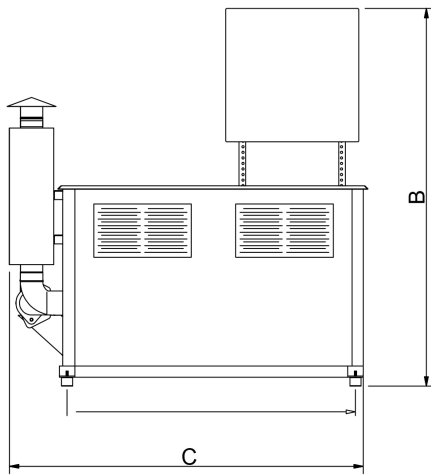

## Vacuum Unit PES-6

### UNIT COMPONENTS

The main components of the PES 6 units are the vacuum pump and the electrical drive motor. Power from the electrical motor to the vacuum pump is transferred by direct coupling, which eliminates maintenance. Inside the rigid and insulated steel housing, are also installed silencer, safety vacuum valve and control sensors.

### CONTROLS

Electrical panel for start/stop and control of the unit is placed outside of the housing. The front of the panel is equipped with push buttons for operation, indication lamps for operation mode / alarm, indication gauge for vacuum level and emergency stop.

The controls also compromise the equipment for ATM filter cleaning, or if selected the Jet-pulse filter cleaning.

Any selection of automatically discharge system for filter separator is also built into the controls, as well as surveying systems for; motor overload, level control for filter separator, timer stop or vacuum timer stop of the unit.

If fault indication from any of these system, unit will stop and fault indication will light up. Sum alarm will be activated simultaneously.

### MISCELLANEOUS

Hose connection: 127 mm  
Material: Steel S 235 JG2  
Painting: System C2, RAL 3003 red

### OPTIONS

- Control Filter 2 x 10m2
- DP-Switch
- DP-Gauge
- Line (Circuit) Breaker
- Pre Designed for Level Control
- Pre Designed for Remote Control 24V
- Pre Designed for Repulse Cleaning
- Pre Designed for Sluice Discharge
- Timer Auto Stop
- Vacuum Timer Stop

Item/Model		PES-6.25	PES-6.33
Dimension. mm	A	1935	1935
	B	1700	1700
	C	1595	1595
Weight, kg (approx)		810	990
Max Vacuum, mbar		290	400
Air Volume m <sup>3</sup> /h unloaded		2200	2200
Electrical motor, kW		25	33
Voltage Frequency, V/Hz		400/50	400/50
Noise Level dB(A) (at 1m distance: no hood/hood)		78/75	80/76
Hose Pipe Connection, dia. mm		127	127
Layout		SD-10033	SD-10033

We reserve the right to alter any specifications without prior notice

#### Manufacturer:

**DISAB-TELLA AB**  
Cedersdalsvägen 1  
SE-186 40 Vallentuna  
Sweden

Tel: +46 (0) 8 514 505 70  
Fax: +46 (0) 8 511 754 66  
E-mail: industrial@disab.com  
www.disab.com

#### Distributor: