

Pressed bends, 2 and 3 mm

Technical catalogue: 2 and 3 mm
 Section: 02
 Page: 6/16
 Revised: 24.10.2012

Diameter for 2 mm: $\phi 100 - \phi 400$ mm.

Diameter for 3 mm: $\phi 150 - \phi 200$ mm.

Pressed bends are made of 2.00 and 3.00 mm sheet metal (s).

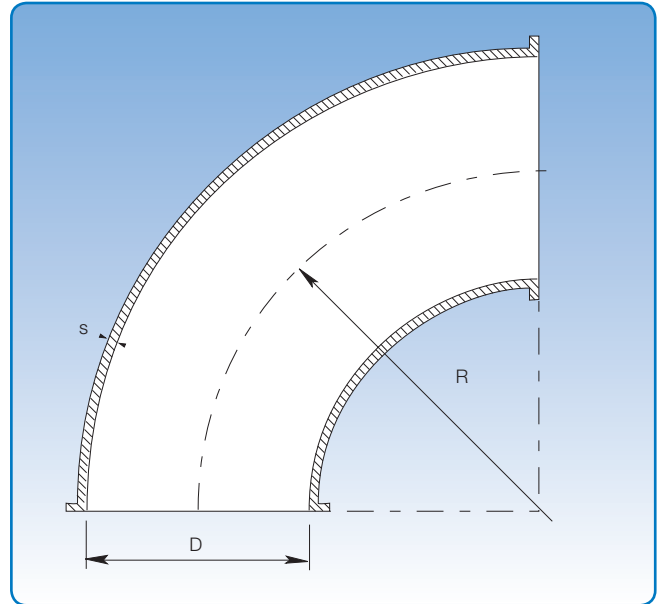

Dimensional specifications are given in the table below.
 $R = 1.5 \times D$ for all dimensions.

When replacing the galvanized bend with 2 – 3.00 mm bend, there may be tolerance differences of ± 20 mm.

Dimensions											
D mm	s mm	90°		60°		45°		30°		15°	
		Item no.	kg	Item no.	kg	Item no.	kg	Item no.	kg	Item no.	kg
100	2,00	1141292	1,20	1141262	0,90	1141242	0,60	1141232	0,40	1141212	0,20
120	2,00	1142292	1,80	1142262	1,20	1142242	0,90	1142232	0,60	1142212	0,30
125	2,00	1143292	2,00	1143262	1,30	1143242	1,00	1143232	0,70	1143212	0,40
150	2,00	1145292	2,90	1145262	2,00	1145242	1,40	1145232	1,00	1145212	0,50
160	2,00	1146292	3,20	1146262	2,20	1146242	1,60	1146232	1,10	1146212	0,70
180	2,00	1147292	3,80	1147262	2,70	1147242	1,90	1147232	1,40	1147212	0,70
200	2,00	1148292	5,00	1148262	3,40	1148242	2,50	1148232	1,70	1148212	0,70
250	2,00	1150292	8,90	1150262	5,90	1150242	4,40	1150232	2,90	1150212	1,40
300	2,00	1151292	12,90	1151262	7,60	1151242	6,40	1151232	4,30	1151212	1,90
350	2,00	1153292	17,80	1153262	12,00	1153242	9,30	1153232	5,20	1153212	3,20
400	2,00	1154292	23,50	1154262	15,70	1154242	11,80	1154232	7,50	1154212	4,10
150	3,00	1145392	4,30	1145362	3,00	1145342	2,20	1145332	1,50	1145312	0,80
160	3,00	1146392	4,80	1146362	3,20	1146342	2,40	1146332	1,60	1146312	1,00
180	3,00	1147392	6,20	1147362	4,10	1147342	3,10	1147332	2,10	1147312	1,10
200	3,00	1148392	7,50	1148362	5,10	1148342	3,70	1148332	2,50	1148312	1,30

The item numbers stated are for primed pressed bends assembled using pull rings [f.b].

Pressed bends are also available for other assembly methods. See p. 7 for assembly methods.