

Pressed bends, galvanised

Technical catalogue: Galvanised
 Section: 01
 Page: 5/16
 Revised: 24.10.2012

Diameter: $\varnothing 80$ - $\varnothing 400$ mm.

Galvanised bends are made of 1.00 mm sheet metal.

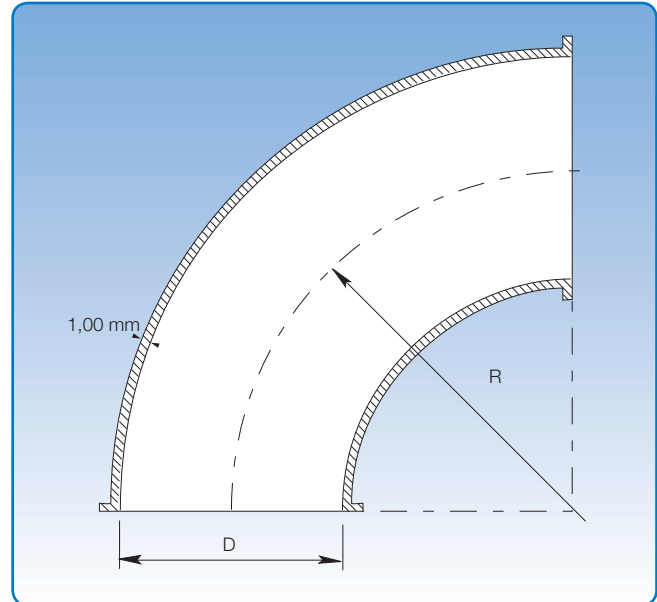

Dimensional specifications are given in the table below. Diameter = (D).
 $R = 1.5 \times D$ for all dimensions.

When replacing the galvanized bend with 2 – 3.00 mm bend, there may be tolerance differences of ± 20 mm.

D mm	Dimensions											
	90°		60°		45°		30°		15°		7.5°	
	Item no.	kg	Item no.	kg	Item no.	kg	Item no.	kg	Item no.	kg	Item no.	kg
80	1170192	0,44	1170162	0,24	1170142	0,20	1170132	0,12	1170112	0,10	1170102	0,10
100	1171192	0,62	1171162	0,40	1171142	0,30	1171132	0,20	1171112	0,14	1171102	0,13
120	1172192	0,90	1172162	0,60	1172142	0,40	1172132	0,30	1172112	0,18	1172102	0,16
125	1173192	0,90	1173162	0,65	1173142	0,45	1173132	0,32	1173112	0,18	1173102	0,18
140	1174192	1,10	1174162	0,80	1174142	0,55	1174132	0,40	1174112	0,24	1174102	0,20
150	1175192	1,50	1175162	0,90	1175142	0,70	1175132	0,50	1175112	0,25	1175102	0,20
160	1176192	1,70	1176162	1,10	1176142	0,80	1176132	0,50	1176112	0,30	1176102	0,29
180	1177192	2,00	1177162	1,30	1177142	1,00	1177132	0,70	1177112	0,40	1177102	0,30
200	1178192	2,50	1178162	1,85	1178142	1,25	1178132	1,00	1178112	0,50	1178102	0,35
225	1179192	3,00	1179162	2,00	1179142	1,60	1179132	1,20	1179112	0,60	1179102	0,37
250	1180192	4,00	1180162	3,00	1180142	2,00	1180132	1,50	1180112	0,75	1180102	0,50
275	11801929	4,80	11801629	3,60	11801429	2,40	11801329	1,80	11801129	0,80	11801029	0,55
300	1181192	5,90	1181162	3,90	1181142	2,90	1181132	2,00	1181112	0,90	1181102	0,60
315	1182192	5,90	1182162	3,80	1182142	2,95	1182132	2,00	1182112	1,12	1182102	0,55
350	1183192	7,30	1183162	4,80	1183142	3,70	1183132	2,55	1183112	1,30	1183102	1,00
400	1184192	10,20	1184162	6,70	1184142	5,10	1184132	3,60	1184112	1,60	1184102	1,20

The item numbers stated are for bends assembled using pull rings [f.b].

Bends are also available for other assembly methods. See p. 6 for assembly methods.