

Tapers, galvanised

Technical catalogue: Galvanised
 Section: 01
 Page: 15/16
 Revised: 01.05.2009

Diameter: $\varnothing 80 - \varnothing 1000$ mm.

Tapers are spot welded and made of 0.90 mm galvanised sheet metal.

When assembling with wide pull rings [f.bb], rapid lock pull rings [f.lyn] and loose flanges [f.b.m.fl] length (L) is increased by 2×50 mm.

State D- and d dimensions when ordering.
 Length L is stated in the table below.

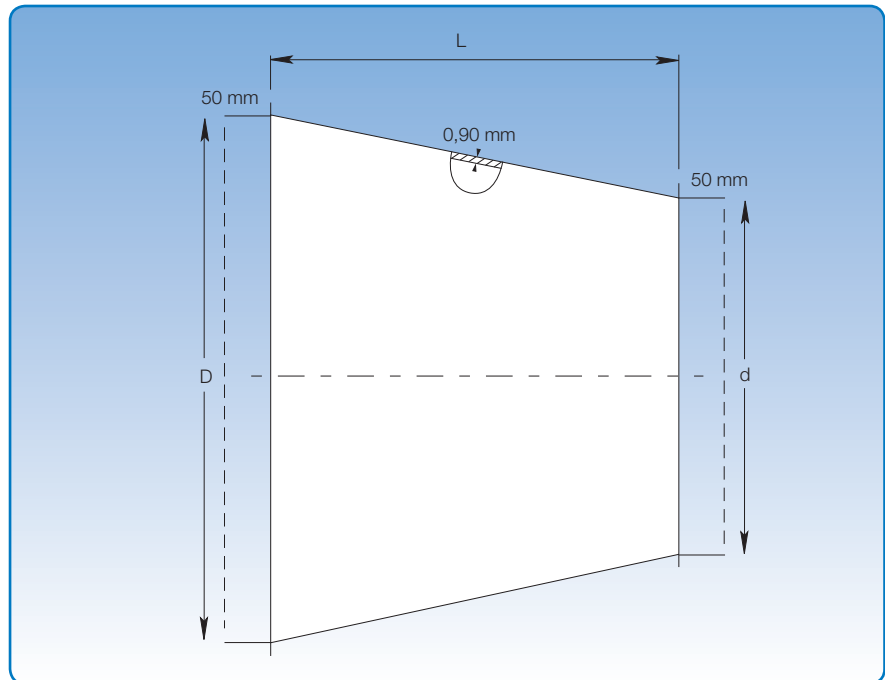

Determining taper length L:

The difference between the larger and smaller diameter (D - d) is plotted on the vertical axis of the coordinate system. By following the line from this point to the intersection, the length (L) can be read at the corresponding point on the horizontal axis.

