

60° branch diverters, pressed, manual, pneumatic and electric

Technical catalogue: Sliding dampers, throttle valves, diverters
 Section: 04
 Page: 6/12
 Revised: 01.05.2009

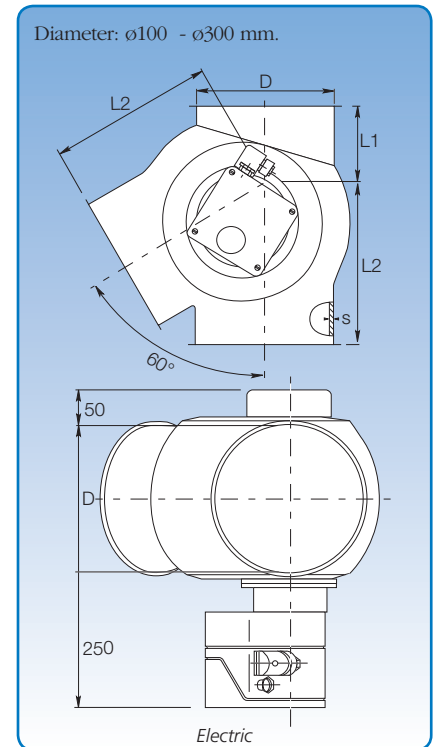
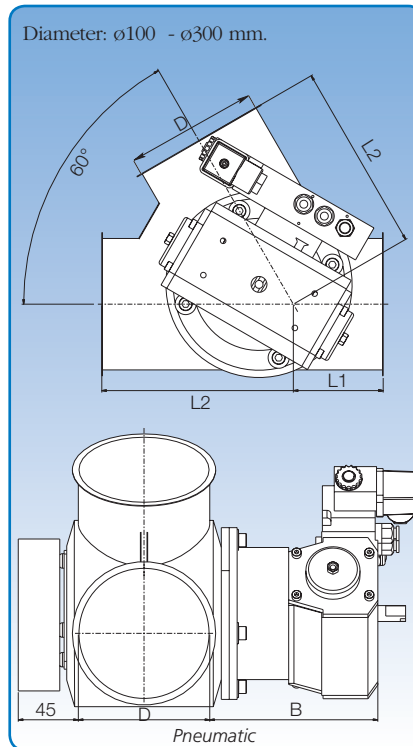
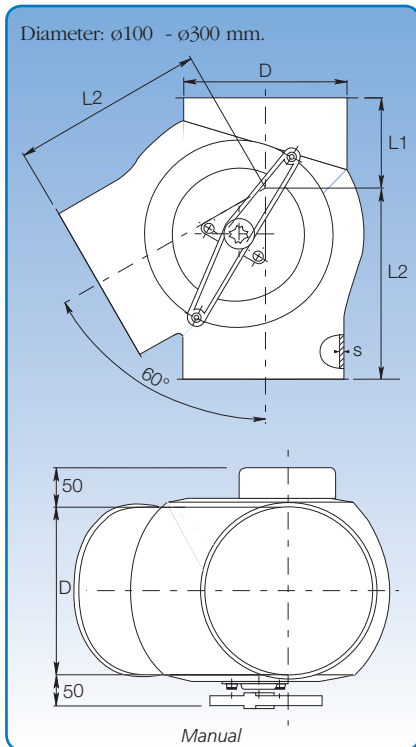

Dimensional specifications are given in the table below.

General

60° branch diverters, pressed, designed for falling and forced direction transport.
 Damper suspended on brass bearings.
 Supplied as standard with left branch.

With pneumatic actuator

The damper is turned by a pneumatic actuator controlled by an electrically-operated valve.
 Solenoid valve: monostable 5/2 valve with 1 x 230 V AC - 50/60 Hz electric coil or 24 V DC. Pneumatic pressure: 4-6 bar.
 Valve setting indicators are available as an optional extra.

With electric actuator

The damper is operated by an electric motor activated by a changeover switch.
 Electrical connection: 230 V AC - 50 Hz or 24 V DC.
 Valve setting indicators are supplied as standard.

Dimensions

Item no. (Man.)	Item no. (Pneu.)	Item no. (Elec.)	D mm	s mm	B mm	L1 mm	L2 mm	Weight (Man.) kg	Weight (Pneu.) kg	Weight (Elec.) kg
1700036	1720036	1710036	100	1,50	145	70	145	2,20	5,20	6,90
1701036	1721036	1711036	120	1,50	145	160	240	6,00	9,00	10,70
1702036	1722036	1712036	125	1,50	145	90	170	4,00	7,00	8,70
1703036	1723036	1713036	150	2,00	145	100	190	5,70	8,70	10,40
1704036	1724036	1714036	160	2,00	145	95	225	6,10	9,10	10,80
1705036	1725036	1715036	180	2,00	145	195	315	11,00	14,00	15,70
1706036	1726036	1716036	200	2,00	145	110	230	8,30	11,30	13,00
1707036	1727036	1717036	250	2,00	145	135	270	13,10	16,10	17,90
1708036	1727336	1717336	300	2,00	145	160	325	19,30	22,30	24,10

The item numbers stated are for branch diverters assembled using pull rings [f.b].

Branch diverters are also available for other assembly methods. See p. 7 for assembly methods.