

Duct silencers

Technical catalogue: Accessories
 Section: 08
 Page: 5/9
 Revised: 01.06.2010

Diameter: 100 mm - 1250 mm.

The duct silencers are used for noise-suppression in ducting systems.

They are made of 1.00 mm galvanised steel sheet, lined with sound-absorbent material.

Can be supplied for fitting to rapid lock pull rings [f.lyn], pull rings [f.b], wide pull rings [f.bb] or loose flanges [f.b.m.fl].

Duct silencers with an internal diameter of > 250 mm can be supplied with baffles.

They can be fitted internally with perforated plates for ducting carrying light materials, or insulation material as options.

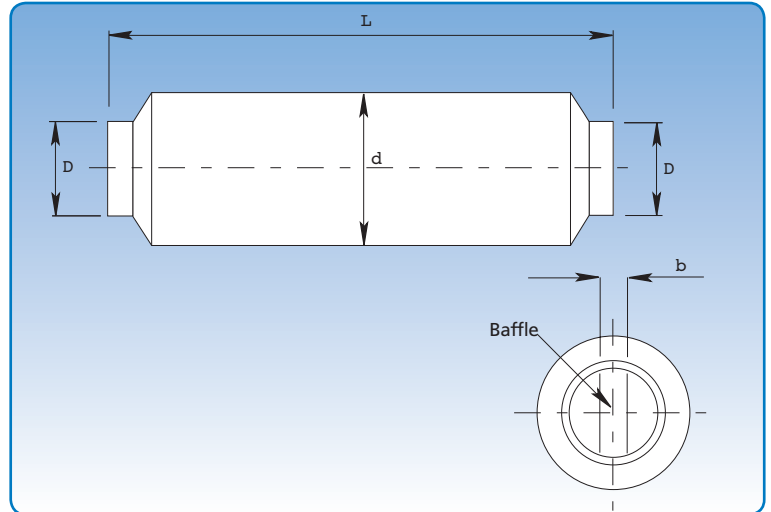

The diagrams show the noise-suppression values for fans and high-pressure fans under the operating conditions stated on the brochure pages. Authorised measurement of noise levels has been performed on the duct silencers.

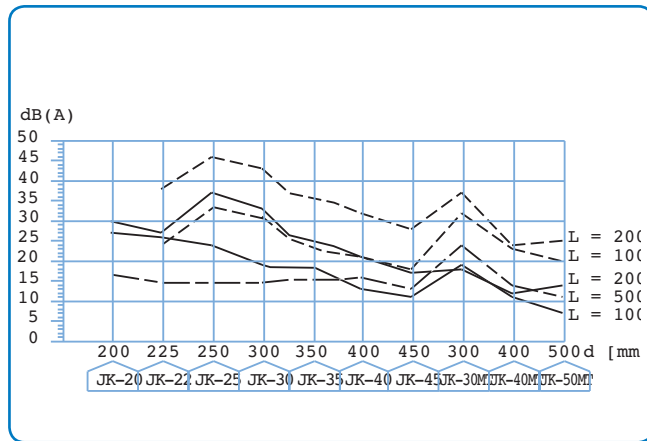

----- = with baffle ————— = without baffle

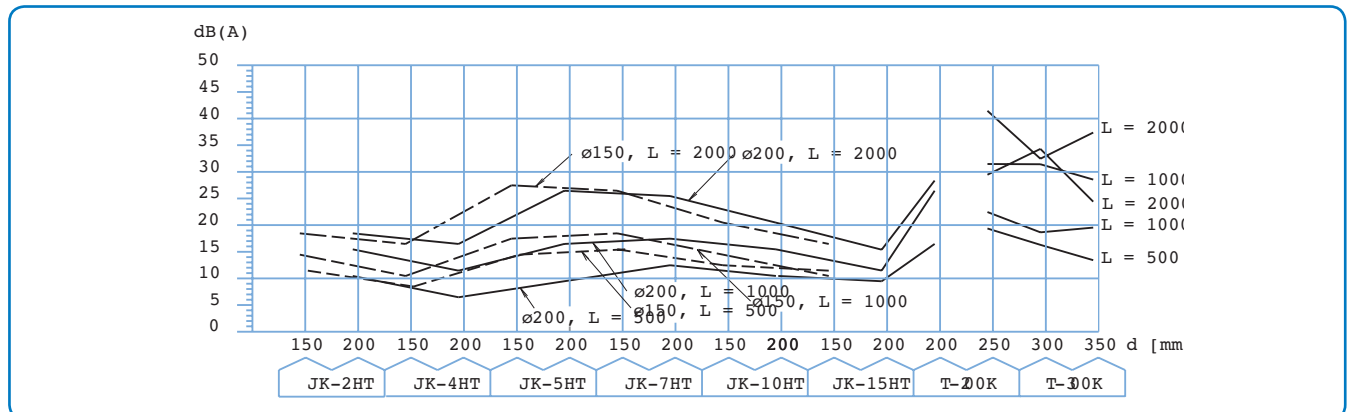
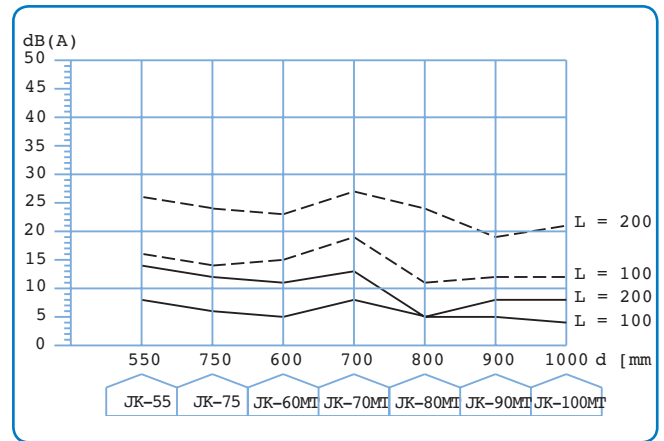

The diagrams show the noise-suppression values in dB(A) for fans.

Duct silencers

Technical data

Technical catalogue: Accessories
 Section: 08
 Page: 6/9
 Revised: 01.06.2010

Noise-suppression values in dB(A) for various frequency bands.

Dimensions				Frequency bands							Weight kg
D mm	d mm	L mm	b mm	Hz 63	Hz 125	Hz 250	Hz 500	Hz 1000	Hz 2000	Hz 4000	
100	300	500		3	12	25	42	35	31	21	6
120	320	500		3	10	19	33	27	24	16	6
125	325	500		3	9	19	32	26	23	15	6,5
140	340	500		2	9	18	30	26	23	15	7
150	350	500		2	9	17	28	24	22	15	7
160	360	500		2	8	16	26	22	20	13	8
180	380	500		1	8	14	24	20	18	13	8,5
200	400	500		1	7	13	22	18	16	11	9
200	400	1000		3	13	25	42	35	31	21	17
225	425	500		1	6	11	20	16	15	10	10
225	425	1000		2	11	22	38	31	28	19	18
250	450	1000		2	10	20	34	28	25	17	20
250	450	1000	100	7	16	27	47	50	43	38	25
275	475	1000		2	10	19	32	26	22	16	21
275	475	1000	100	6	15	26	44	48	38	44	26
300	500	1000		2	9	17	29	23	18	14	22
300	500	1000	100	6	13	25	41	46	33	50	28
315	515	1000		2	8	16	27	21	17	11	24
315	515	1000	100	5	12	22	39	44	31	27	30
350	550	1000		2	7	14	24	18	15	9	26
350	550	1000	100	4	10	20	36	39	28	23	32
400	600	1000		2	6	12	21	14	13	8	29
400	600	1000	100	4	9	18	31	35	25	20	36
450	650	1000		3	6	11	19	11	11	6	32
450	650	2000		5	11	19	38	20	17	10	60
450	650	1000	100	4	8	15	29	31	21	17	40
450	650	2000	100	7	14	28	50	50	37	32	73
500	700	1000		4	6	11	19	8	8	4	37
500	700	2000		6	11	18	35	16	14	8	66
500	700	1000	100	5	7	14	25	28	20	15	45
500	700	2000	100	8	13	25	47	50	37	30	80
550	750	1000		3	5	10	17	8	7	4	38
550	750	2000		5	10	17	32	15	13	7	71
550	750	1000	100	4	6	13	22	26	18	14	47
550	750	2000	100	7	12	23	42	50	35	27	86
600	800	1000		3	5	9	15	7	6	3	42
600	800	2000		5	9	16	28	14	12	6	77
600	800	1000	100	4	6	11	20	24	16	11	52
600	800	2000	100	7	11	20	38	46	32	21	93
630	830	1000	100	4	6	11	18	22	15	10	54
630	830	2000	100	7	11	20	34	42	30	20	97
650	850	1000	100	3	6	10	17	21	14	9	55
650	850	2000	100	5	11	19	31	41	27	17	100
700	900	1000	200	5	7	14	24	21	24	14	69
700	900	2000	200	8	14	26	45	42	46	27	123
750	950	1000	200	5	6	11	20	18	17	11	74
750	950	2000	200	8	12	21	38	36	33	20	131
800	1000	1000	200	4	6	11	19	17	16	10	79
800	1000	2000	200	7	12	21	36	34	30	19	139
850	1050	1000	200	3	5	10	17	16	15	9	84
850	1050	2000	200	5	11	19	32	32	29	18	147
900	1100	1000	200	3	5	10	15	15	14	9	89
900	1100	2000	200	5	11	18	30	30	27	17	155
950	1150	1000	200	3	5	9	14	14	13	8	94
950	1150	2000	200	5	10	17	27	27	25	16	164
1000	1200	1000	200	3	5	9	14	13	13	8	99
1000	1200	2000	200	5	10	17	26	25	24	15	172
1250	1450	1000	200	2	4	7	11	11	10	5	126
1250	1450	2000	200	4	7	13	20	21	19	11	214